

4. To set the gear indication each gear to be programmed will flash on the display. Select 1st gear, release the clutch, increase the engine RPMs to approximately half of the RPM range of the engine and hold the RPMs steady, then press the black button once to program 1st gear selection, number 2 will now flash, select 2nd gear, hold the engine RPMs steady again at half of the RPM range, then press the black button and continue until you have reached and programmed the gearboxes top gear. Now allow the engine to idle and select neutral.

Now press and hold the black button..... see. **INSTRUCTION NOTE!**

5. To set the speed indication you must operate the motorcycle at a known steady 30mph/48kmh. Once you have reached this speed press the black button. If you have made a mistake you can set the speed indication again during this section of the set-up procedure by repeating this process.

Now press and hold the black button..... see. **INSTRUCTION NOTE!**

6. To change between KMH and MPH press the black button to select the desired indication.

Now press and hold the black button..... see. **INSTRUCTION NOTE!**

7. To change between fahrenheit and centigrade readings press the black button to select the desired indication.

Now press and hold the black button..... see. **INSTRUCTION NOTE!**

8. To set the oil pressure loss indication parameters press the black button.

Now press and hold the black button..... see. **INSTRUCTION NOTE!**

9. To set the backlight colour parameters press the black button to toggle between red and blue backlighting.

To save the backlight colour parameters and authenticate the entire Micro Dash parameters press and hold the black button. Once the lap-timer section of the Micro Dash has counted down again ie: 05: 04: 03: 02: 01: 00 the Micro Dash will be programmed and will be in normal run mode.

FINE TUNING THE MICRO DASH PARAMETERS

If you wish to make minor adjustments to any of the Micro Dash parameters this can be done by entering the set-up mode again. You can re-adjust any of the settings within each section of the Micro Dash mentioned in **SETTING THE MICRO DASH PARAMETERS** on page 3.

To skip a section and move straight onto the next section without altering the parameters in the indicated flashing section press and hold the black button, the lap-timer section of the Micro Dash will countdown ie: 05: 04: 03: 02: 01: 00, when zero is reached release the button and you will move to the next section without making any alterations. This sequence can be repeated until you reach a section of the Micro Dash parameters you wish to adjust.

Once in the section you wish to adjust carry out the new setting as described on page 3. and save the new setting by pressing and holding the black button, then the lap-timer section of the Micro Dash will countdown ie: 05: 04: 03: 02: 01: 00, when zero is reached release the button. You can now continue to make an adjustment in the next section or simply switch off the ignition/engine to save and authenticate the new settings.

FINE TUNING EXAMPLE: You wish to increase the RPM indication point so the shiftlights illuminate closer to the rev limiter.

1. Re-enter the set-up as described on page 3. Move onto section 3. setting the tachometer/RPM scale and shiftlight indication point.

2. Increase the RPMs slowly until the centre shiftlight LEDs illuminate, then increase the RPMs `1 RPM segment bar' at a time until you think you have increased the RPMs sufficiently to achieve

1. Secure the Micro Dash into the desired position with the supplied mounting brackets and fitting kit. The brackets can be easily bent into desired profiles. Position the Micro Dash so that when you are in the racing position you can see directly into the centre of the shiftlight LED array. Misalignment of the shiftlight LEDs will result in poor shift indication and LED brightness!

CONNECTING THE UNIVERSAL WIRING HARNESSSES

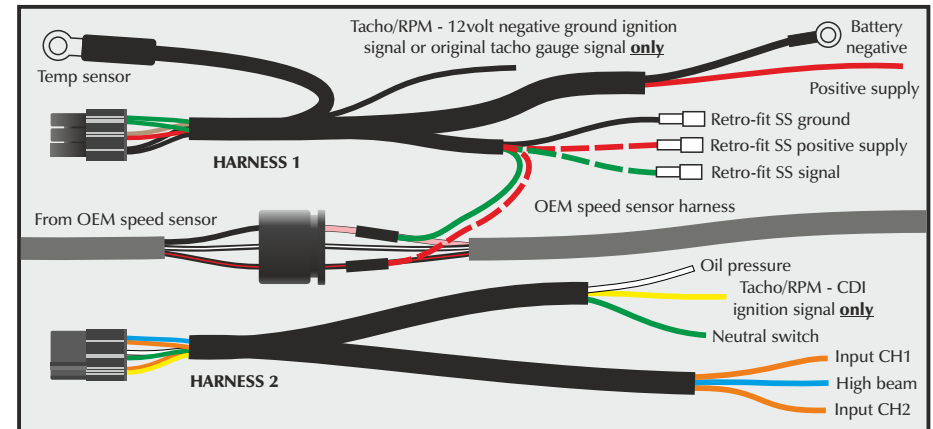

1. Connect the Micro Dash loom connectors to the corresponding universal wiring harness connectors. Route the harnesses through to the battery area and connect the black eyelet wire (**Harness 1**) to the negative battery terminal only. Connect the long red positive supply wire (**Harness 1**) to a suitable ignition power-on wire. An ignition power-on wire is a wire that receives +12 volts when the ignition is switched on, ie: the rear brake light switch supply wire etc.

NOTE: The motorcycle/vehicles OEM speed sensor must be connected to the universal wiring harness speed sensor wires (**Harness 1**) to enable the Micro Dash to indicate gear selection and speed. If there is no OEM speed sensor present then you will be required to fit the Retro-fit speed sensor **TLS-SS**. Typically the OEM speed sensor has 3 wires, a negative ground wire, positive supply wire and a speed signal ground wire. The OEM speed sensor may lose its positive supply once you have removed the original gauges, this positive supply will be replaced when connecting the universal harness speed sensor red wire (**Harness 1**).

2. Using a digital volt meter locate and identify the 3 different wires on the OEM speed sensor and their function, either ground, positive supply or signal. Connect the green wire (**Harness 1**) to the OEM speed sensors signal wire. Only connect the red wire (**Harness 1**) to the OEM speed sensors positive supply wire if the original positive supply has been lost when disconnecting the original OEM gauges. The black wire (**Harness 1**) does not normally need to be connected to the OEM speed sensors ground wire. (If you are using the optional Retro-fit speed sensor then connect the corresponding wires accordingly, red to red, black to black and green to green (**Harness 1**). See **FITTING THE RETRO-FIT SPEED SENSOR** mentioned on page 2.

ATTENTION! Identify what type of ignition system your engine has, either `+12volt negative ground triggering ignition' or `CDI ignition' before commencing with the following section.

3. Connect the corresponding tachometer/RPM sensing wire, either black wire (**Harness 1**) or yellow wire (**Harness 2**) to any one of the ignition coil signal wires. In some cases connecting the black